



CATALOG#: \_\_\_\_\_  
 PROJECT: \_\_\_\_\_  
 TYPE: \_\_\_\_\_

# Series MPS

## Midsize Electrical Inverter

MPS Series inverter systems are designed to provide sinusoidal AC emergency power to connected incandescent, fluorescent, or LED fixtures between 20 and 55 watts.

Surface, recessed or ceiling T-Grid mount models are designed for easy installation either on or near controlled fixtures. MPS models support Normally-ON, Normally-OFF, switched operation or any combination thereof (see wiring diagram).

### HOUSING

Heavy duty steel cabinet is finished in white baked-on powder paint providing scratch and corrosion resistance. Optional special color paint (-SP) finishes are available. Consult factory.

### MOUNTING

**Surface Mount:** Surface mount models are designed for mounting to walls by means of keyhole slots provided in the back of the unit housing.  
**Recess Mount:** Recess models provide recess mounting holes on both sides of the enclosure.  
**T-Grid Mount:** Housing design allows simple drop-in installation between t-grid runs. Safety wires (supplied by others) are required for attachment to building structure.

### WIRING

Connection to an unswitched AC circuit is required by the NEC. Wiring access is provided for by conduit knockouts in the unit housing. MPS Series models also provide knockouts in the back of the housing for rear wiring from standard electrical boxes when surface mounting.

### WARRANTY LISTING

- Unit (excluding lamps): Full coverage against defects in materials and workmanship for 3 years from date of shipment
- Battery: 3 years Lead-Acid, 5 yrs NiCd full warranty plus an additional 7 years of pro-rata coverage.
- All models are UL924 Listed and meet NFPA 101 Life Safety Code, NEC, OSHA, Local and State Codes
- UL Listed for damp locations (20° - 30°C)

*True Sinusoidal  
Output Power*



### DIMENSIONS (Surface Mount)

MPS-35 & MPS-55: 14.75"L x 7.375"H x 4.375"W  
 MPS-20& MPS-32: 14.75"L x 7.375"H x 3.125"W

### FEATURES & BENEFITS

- For powering incandescent, fluorescent, induction and LED fixtures (consult factory for compatibility for other lamp types)
- True sinusoidal AC pulse width modulated (PWM) design provides clean 60Hz. emergency output
- Universal 120/277VAC, 60Hz. input/output
- Unit capacities of 20W to 55W  
"Soft Start" design reduces fixture inrush current
- Surface, recessed or T-Grid mount models
- Lumen output from fixture is 100% of nominal
- Unique design eliminates compatibility problems with LED drivers as well as fluorescent ballasts
- Normally-ON and/or Normally-OFF load output
- Provisions for local switching capability - Always-ON during emergency conditions regardless of local switch position
- Temperature compensated, dual-mode charger includes low voltage disconnect feature to provide protection against battery deep discharge
- Maintenance-free Lead-Calcium and premium grade Nickel-Cadmium battery models offered  
Control panel with momentary test switch, AC-ON, Charge-ON and Inverter-ON LED indicators
- Battery circuit fuse protected
- Reverse battery and AC lockout protection

STANDARD | OPTIONAL





CATALOG#: \_\_\_\_\_  
 PROJECT: \_\_\_\_\_  
 TYPE: \_\_\_\_\_

# Series MPS

Midsize Electrical Inverter

## ELECTRICAL SPECIFICATIONS

### Input

- Input Voltages: 120 or 277VAC  $\pm 10\%$
- Input Frequencies: 60Hz  $\pm 2\%$
- Input Protection: Provided by Service Panel, Rated 20A max.

### Output:

- Output Voltages: 120 or 277VAC (60Hz)
- Efficiency Rating: 98% at full rated load (line)
- Waveform: Sinusoidal (digitally controlled, PWM design)
- Static Voltage:  $\pm 5\%$  during battery discharge. 0-100% linear load.
- Output Frequencies: 60Hz.  $\pm 0.3$ Hz during emergency cycle
- Output Distortion: Less than 3% THD (linear load)
- Transfer Time: Less than 1.0 second
- Load Power Factor Range: 0.44 Lead to 0.44 Lag
- Minimum Loading: 0% of rated system capacity
- Output Protection: Inverter fuse

## LOAD COMPATIBILITY

MPS model's clean, sinusoidal AC output will operate incandescent lamps as well as all common fluorescent and LED lamp types. Consult factory for compatibility with all other lamp types.

Lighting loads are driven at 100% output for the entire emergency power cycle. This outstanding feature translates into greater occupant egress vision and safety.

## IMPROVED AESTHETICS

The MPS system's sinusoidal AC output design eliminates voltage drop and proximity concerns. This allows added flexibility in installation location as MPS units can be installed hundreds of feet from the units they power. This means MPS units to be located conveniently out of sight in closets or utility rooms without interrupting architectural aesthetics.

In lighting applications, no special or additional emergency fixtures are necessary. Simply designate and connect existing lighting fixtures, either interior or exterior, to the MPS unit for emergency operation eliminating the need for exposed, stand-alone emergency luminaires.

## GENERAL SPECIFICATIONS

MODEL NUMBER	HOUSING SIZE	INPUT / OUTPUT VOLTS	90 min. CAPACITY (Watts/VA)	SYSTEM WEIGHT*		BATTERY TYPE	TEMP. RANGE (°C)	POWER CONSUM. (Max.)	BATTERY VOLTAGE (VDC)	DC INPUT CURRENT (A <sub>dc</sub> )	INPUT CURRENT		THERMAL OUTPUT in BTUs	
				Lbs.	Kg.						120VAC (max)	277VAC (max)	STANDBY	EMERGENCY
MPS-32	Small	120/277	32/32	14.0	6.4	Lead-Calc	20-30°	9W	12	3.4	0.34A	0.15A	7	32
MPS-55	Large	120/277	55/55	18.0	8.2	Lead-Calc	20-30°	9W	12	5.7	0.54A	0.23A	7	47
MPS-20	Small	120/277	20/20	11.0	5.0	NiCad	0-50°	9W	12	2.1	0.25A	0.11A	31	22
MPS-35	Large	120/277	35/35	12.0	5.4	NiCad	0-50°	9W	12	3.8	0.37A	0.16A	31	35

\* System weights shown include installed batteries

### SYSTEM OPTIONS (1) (2)

ADD SUFFIX	DESCRIPTION
-S	Surface Mount Housing
-R	Recess Mount Housing
-T	Plenum Rated Ceiling T-Grid Mount Housing
-SP	Special Housing Color (specify)
-RTS	Remote Test Switch Panel <sup>(3)</sup>
-SDT	Self-Testing / Self-Diagnostics <sup>(3)</sup>
-CEC	Title 20 Compliant

**Notes:**

- (1) Other options available. Consult factory.
- (2) Some options may impact product UL listing. Consult factory.
- (3) For more information, separate specification sheets are available on the -RTS and -SDT options. Consult factory.

### DRAWINGS & IMAGES

#### Standard Surface Mount Housings

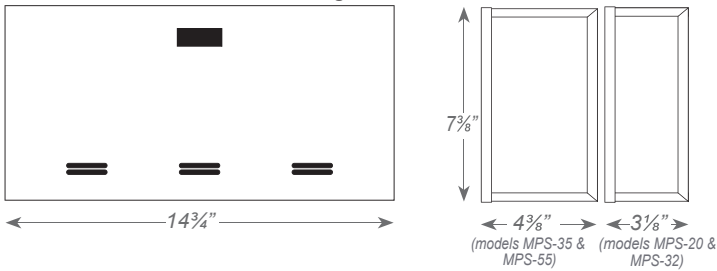

#### Recessed Mount Housings

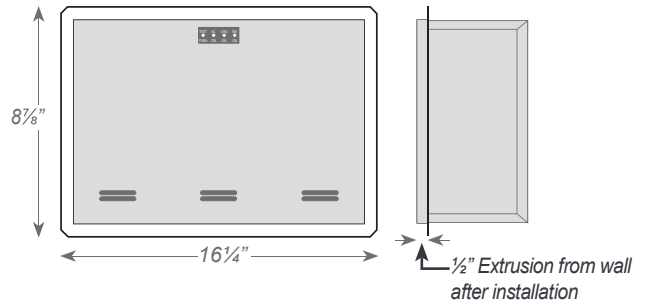

#### Optional Ceiling T-grid Mount Housing

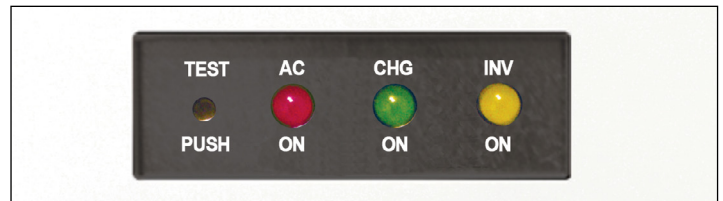
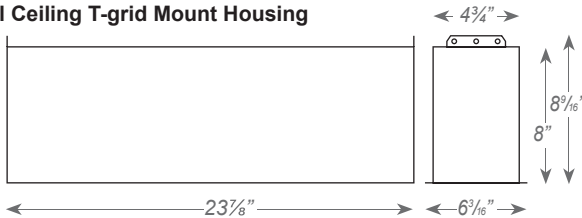

### SYSTEM MONITORING PANEL

All MPS systems provide a monitoring panel on the front of the unit to show operating status at all times. The panel provides a test switch for user initiated system tests and a 3-LED array that provides an intuitive visual indication of unit readiness.

We reserve the right to change design, materials, LEDs and finish in any way that will not alter installed appearance or reduce function and performance.



CATALOG#: \_\_\_\_\_  
 PROJECT: \_\_\_\_\_  
 TYPE: \_\_\_\_\_

# Series MPS

Midsize Electrical Inverter

## OPERATION

Upon failure of the normal utility power the MPS unit is automatically turned on by a solid-state switching circuit and provides a minimum of 90-minutes of emergency power to the connected load. Lumen output will be maintained at 100% of the lamp’s rating throughout the entire duration. A solid-state low voltage disconnect circuit is used to protect the battery from being severely damaged by a deep discharge. When normal utility power is restored, the unit switches the load back to normal utility operation and the fully automatic, temperature compensated, dual mode charger begins to restore the battery; bringing it to full charge within UL924 specified parameters. A brownout sensing circuit insures proper operation during “low line” conditions.

### BATTERY

**Battery:** Sealed Lead Calcium (10 year life) or Sealed Nickel-Cadmium (15 year life)

**Battery Voltage:** 12VDC for all MPS models

**Runtime:** 90-minutes standard. Other runtimes available, consult factory.

**Battery Protection:** Low Voltage Battery Disconnect protects the battery from being severely damaged by deep discharge during prolonged power failures. DC Overload and Short Circuit Protection provided by a DC input fuse.

### CHARGER

**Charger Type:** Fully automatic, temperature compensated, dual-mode charger

**Power Consumption:** 9W max. (All models)

**Recharge Duty Cycle:** Meets UL924 requirements

**Controls:** Momentary test switch, AC-ON, Charge-ON and Inverter-ON LED indicator lights

**Safety Circuitry:** AC Lockout prevents battery discharge prior to initial unit power-up. Brownout Protection automatically switches the unit to emergency mode when utility voltage is significantly reduced.

### ENVIRONMENTAL

**Altitude:** < 10,000 feet (3,000m) above sea level without derating.

**Operating Temperature Range:** Lead-Calcium Models: 20°C to 30°C

Nickel-Cadmium Models: 0°C to 50°C

**NOTE:** Optimum system performance between 20°C and 30°C; temperatures outside of this range will affect battery performance and life.

**Relative Humidity:** 95% non-condensing

## MPS SYSTEM ADVANTAGES

Compared to traditional discrete emergency lighting units, the MPS Series provides emergency illumination from a single power source resulting in lower maintenance overhead and routine testing expenses. MPS units lower installation costs by powering existing lighting fixtures during emergencies. And because connected fixtures are driven at full brilliancy, they provide far superior egress lighting and deliver improved occupant safety.

### WIRING DIAGRAMS

#### NORMALLY ON LOADS

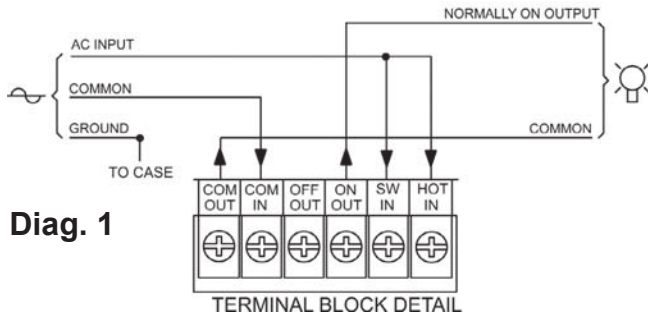

Diag. 1

#### NORMALLY OFF LOADS

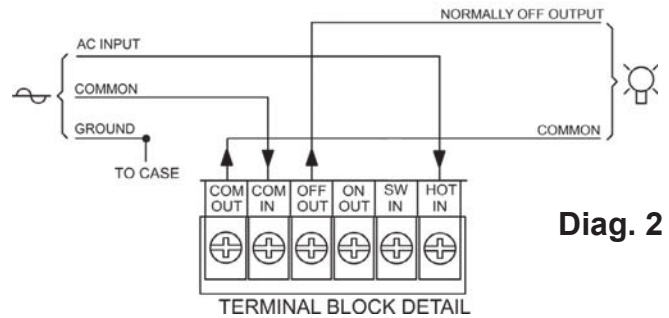

Diag. 2

#### NORMALLY ON & OFF LOADS

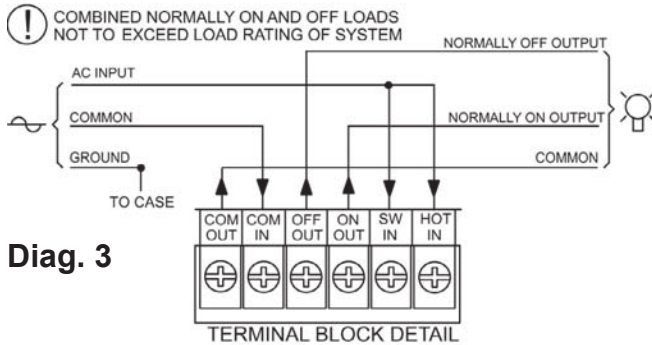

Diag. 3

#### SWITCHED LOADS

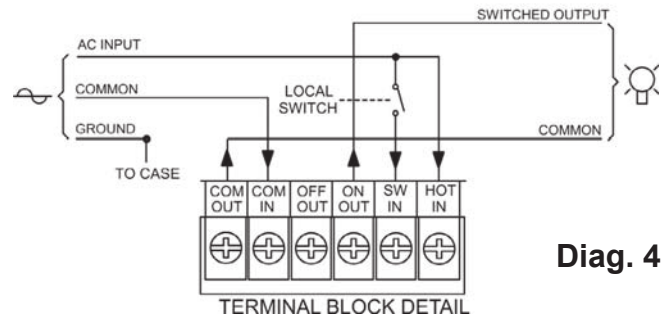

Diag. 4

⚡ INPUT SUPPLY FROM UNSWITCHED UTILITY RATED 20 AMPS MAXIMUM.  
 💡 OUTPUT(S) TO LIGHTING LOADS

### VOLTAGE SELECTION DETAIL

#### VOLTAGE SELECT DETAIL

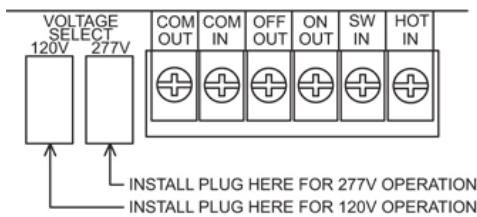

NOTE: Voltage selection plug is shipped loose from factory. User installation required.



CATALOG#: \_\_\_\_\_  
PROJECT: \_\_\_\_\_  
TYPE: \_\_\_\_\_

Series MPS  
Midsize Electrical Inverter

### **SUGGESTED SPECIFICATIONS**

An inverter system with sinusoidal output shall be supplied capable of powering any combination of lighting fixtures, including incandescent, fluorescent, induction and/or LED light sources without compatibility problems.

The system shall transfer in less than 1.0 second to reliably back up lighting fixtures without loss of illumination and operate any and all connected lighting fixtures at full lumen output during the complete 90-minute discharge cycle.

The input voltage shall be the same as the output voltage and shall be single phase 120/277 volts, 60Hz. Output capacity will be (375W/375VA) (600W/600VA) for a minimum duration of 90-minutes.

The design shall be a standby, off-line inverter with an on-line efficiency of 98%; on-line double conversion UPS systems shall not be considered acceptable alternatives. LPS System output shall be a PWM generated sine wave with less than 3% total harmonic distortion with "Soft Start" design reduces fixture inrush current. The system shall also provide short circuit and overload protection as standard.

An intuitive three LED display shall provide system operational information at a glance and alert user to any malfunction in system performance. Authorized maintenance personnel shall have access to the system's controls while being protected from any live exposed connections.

Protective devices shall include AC Line fuses, DC input breaker and a DC input fuse. The entire LPS system, including batteries, shall be incorporated into compact cabinetry which shall have provisions for surface mounting.

System shall be capable of providing up to 4 switch bypass circuits, adjustable output or 2.5 to 10 volt dimmer bypass and self-test/self-diagnostics, were necessary.

System shall utilize a sealed lead calcium battery with a 10 year design life. The charger shall be temperature compensated, dual mode type, and recharge the batteries as per UL924 guidelines. Entire system shall be tested, approved, and labeled to UL924 Emergency Lighting and Power Systems standards.