

SER-Cont. Run Installation Instructions

Overview

WARNINGS

- This product must be installed in accordance with all applicable codes by a person familiar with the product.
- Each fixture must be **properly supported** during install.
- **DO NOT** join fixtures on the floor prior to lifting, or damage will occur.
- **Before beginning installation**, review our complete list of warnings by visiting www.saylite.com/warnings.

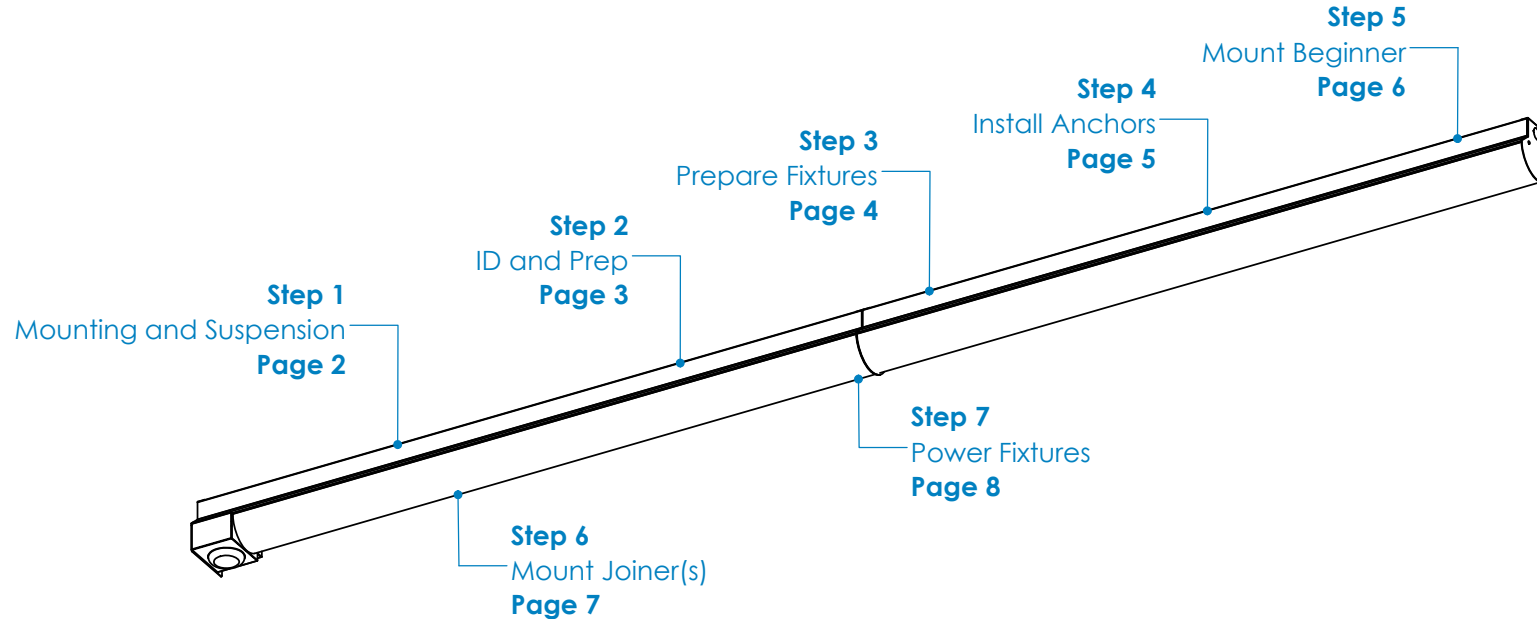

Your particular build may vary.

2020© Saylite | 2055 Luna Road, Suite 142, Carrollton, TX 76005 | www.saylite.com

SER-Cont. Run Installation Instructions

Step 1 - Mounting and Suspension

Mounting Options

Drywall or other hard surfaces - Anchored Screws

- Install anchors at mounting locations.
- Ensure anchors are secure.
- Prepare fixture for mounting.

Other hard surfaces include: wood, sheet metal panels, steel beams, concrete or masonry. Use hardware appropriate for each surface and material type.

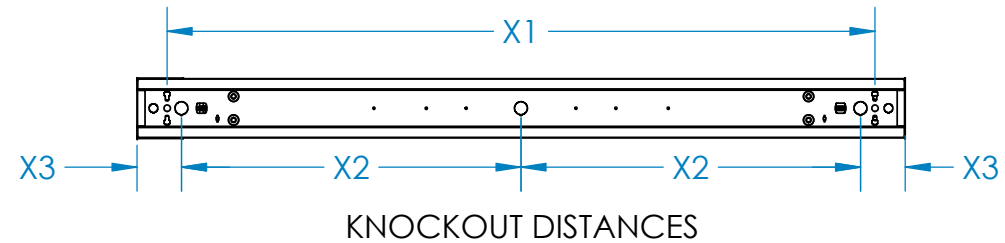

Suspension Locations

X = Suspension Dimensions

Refer to Assembly Drawings and building plans to determine exact mounting, suspension points, and power feed locations.

SER-Cont. Run Installation Instructions

Step 2 - Identification and Preparation

A. Identify Fixtures

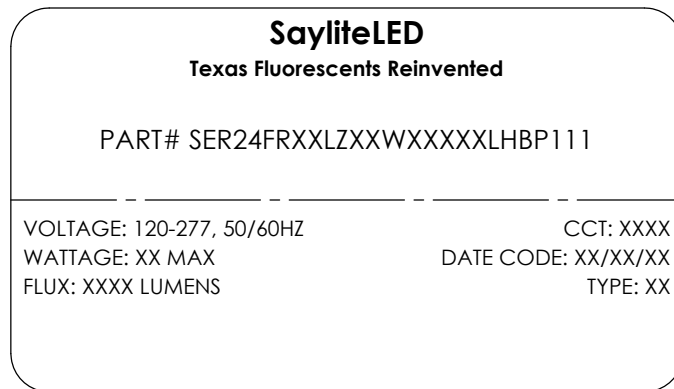

B. Tools Needed

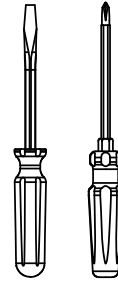

Screwdrivers

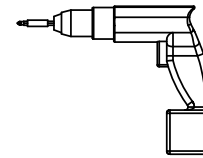

Drill

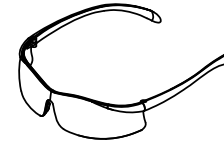

Safety Glasses

- Use labels found on the box and inside the fixture bodies to identify bodies.
- **NOTE:** Locations of labels can vary.
- Remove all fixtures from their boxes.
- Organize fixtures based on their labels at the install location.

- Always use proper safety equipment when installing fixtures.
- Tools shown are recommended for standard install. Tools needed may vary based on actual install location conditions.

Kitted Hardware

- Saylite has provided the items listed here, with their Saylite part numbers listed. These items can be found in separate boxes shipped with the fixture.
- Ensure all parts are accounted for and set them aside until needed.
- Any additional hardware needed for this installation will be provided by others.

SER-Cont. Run Installation Instructions

Step 3 - Prepare the Fixtures

A. Remove Lenses

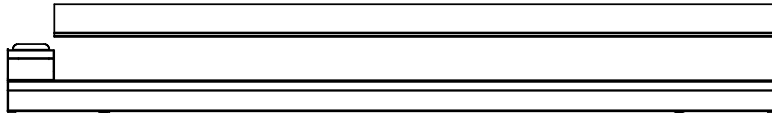

- Remove the lens from each fixture and set aside in a safe location for later use.

B. Remove Gear Trays

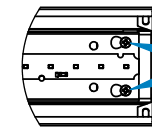
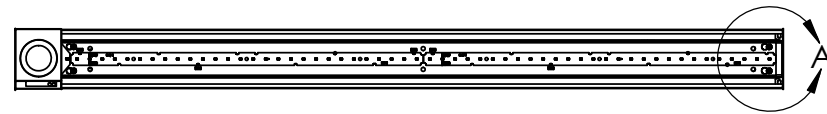

Loosen

DETAIL A
SCALE 1 : 6

Slide →

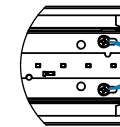
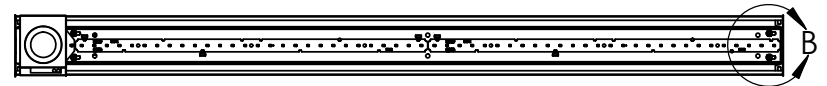

Lift out when
aligned

DETAIL B
SCALE 1 : 6

- Loosen the screws securing the gear tray on each end of the fixtures.
- Slide the fixtures until the screws are centered in the tops of the key holes.
- Lift the gear tray out of the fixture bodies and set aside in a safe location for later use.

SER-Cont. Run Installation Instructions

Step 4 - Install Anchors

A. Transfer Measurements

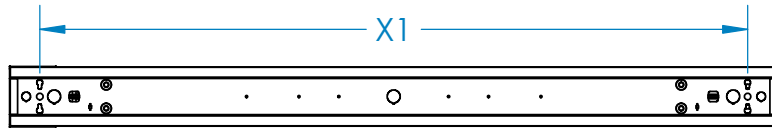

- Refer to assembly drawings for mounting location distances and knockout locations, transfer to mounting surface.

B. Install Anchors

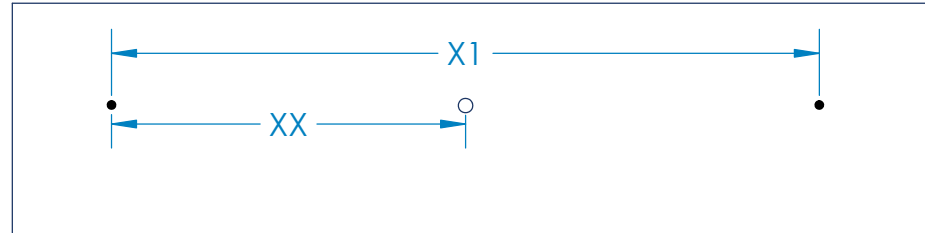

- Install the anchor screws (not provided) to the mounting surface.
- Drill a hole for the power feed supply at desired knockout location.

SER-Cont. Run Installation Instructions

Step 5 - Mount Beginner Fixture

A. Mount Fixture Body

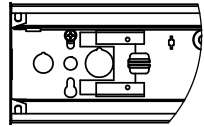
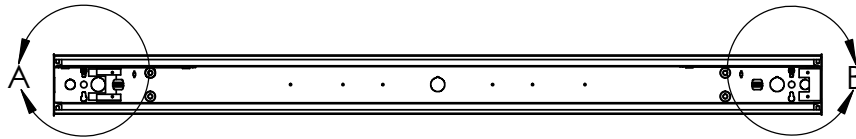

DETAIL A
SCALE 1 : 6

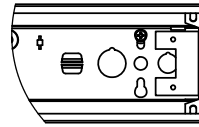

DETAIL B
SCALE 1 : 6

- Mount the fixture body to the anchor screws. Tighten the anchors to secure the fixture to the mounting surface.

B. Remove End Knockout

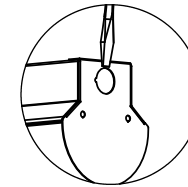
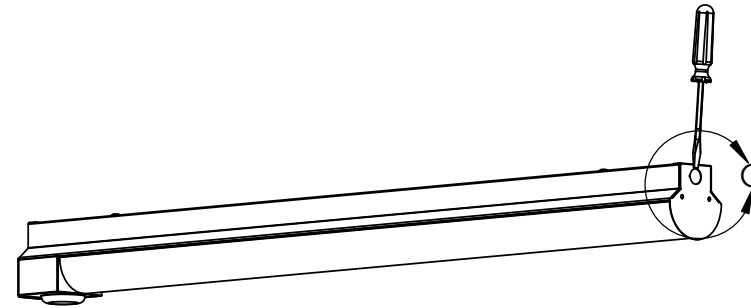

DETAIL C
SCALE 1 : 6

- Use a flat head screwdriver and gently pry outward to remove the end knockout from the beginner fixture.
- Prior to mounting the joiner fixtures remove the desired end knockout(s).

SER-Cont. Run Installation Instructions

Step 6 - Mount the Joiner Fixture(s)

A. Mount Fixture(s)

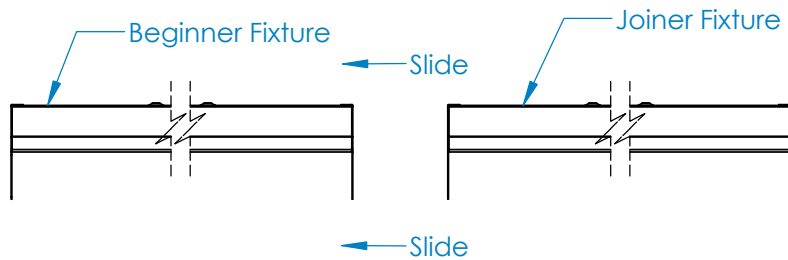

- Mount the joiner fixture and slide until end is touching beginner fixture.
- Tighten anchor screws to secure joiner fixture to mounting surface.

B. Connect and Secure Fixture(s)

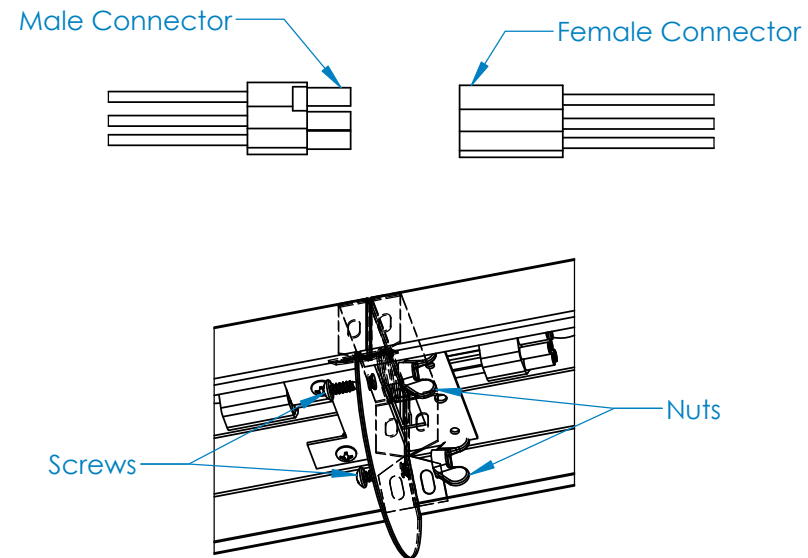

- Connect the wire harness to the appropriate end of the beginner and joiner fixtures.
- Once the fixtures are flush against one another, use 2 each bolt and nut to secure the fixtures to each other.
- A chase nipple may also be threaded thru the wire harness knockouts of each fixture for extra security.
- Repeat this step for remaining joiner fixtures.

SER-Cont. Run Installation Instructions

Step 7 - Power the Fixtures

A. Reinstall Components

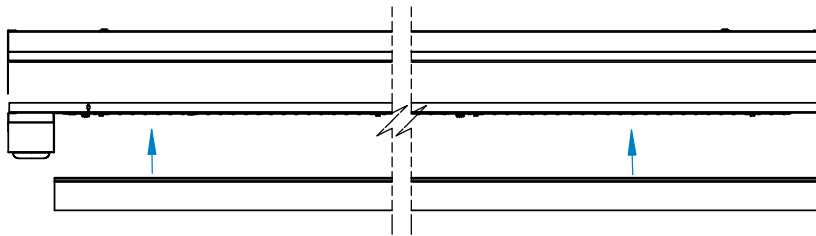

- Reinstall the components removed in Step 3.
- Set the gear tray in the body and align with fixture mounts. Slide gear tray back and tighten screws to secure. Replace lens in each fixture.

B. Wire the Fixtures

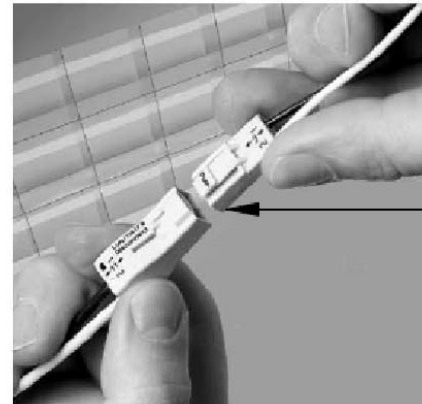

WIRING LEGEND		
BLACK	HOT	Line Voltage
WHITE	NEUTRAL	Line Voltage
GREEN	GROUND	
GRAY	DIMMING	0-10V DC
VIOLET	DIMMING	0-10V DC

- Wire fixture to the incoming power supply using the provided quick disconnect clip as shown.
- For dimming option, refer to wiring legend above.
- Use UL approved connectors only. Follow all local, state and national codes.
- Fixture installation is now complete.