

LWD-Retrofit Installation Instructions

Overview

WARNINGS

- This product must be installed in accordance with all applicable codes by a person familiar with the product.
- Each fixture must be **properly supported** during install.
- **DO NOT** join fixtures on the floor prior to lifting, or damage will occur.
- **Before beginning installation**, review our complete list of warnings by visiting www.saylite.com/warnings.



Texas Fluorescents Reinvented

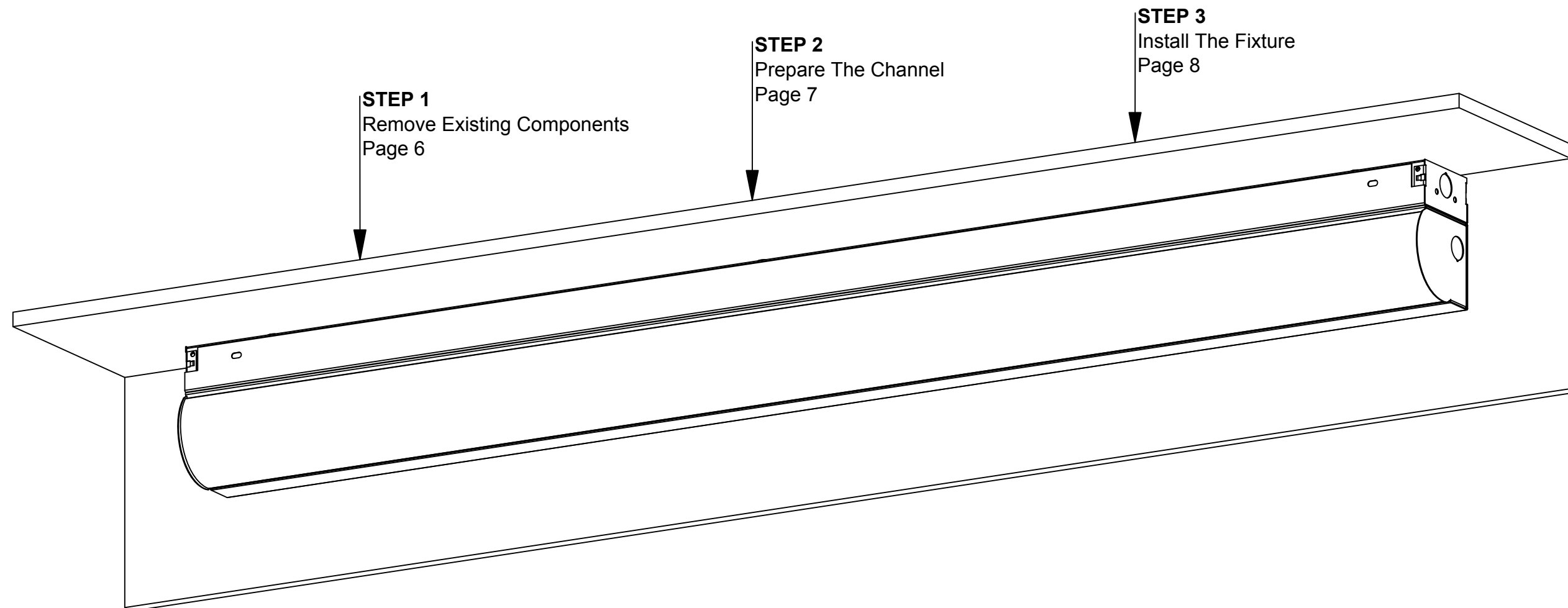

We believe
in the power
of light.



Your particular build may vary.

2019© Saylite | 2055 Luna Road, Suite 142 Carrollton, Texas 75006 | www.saylite.com

1 of 8

Form BWE - ARK-Retrofit V3 10/19

LWD-Retrofit Installation Instructions

Preparation - Tools/Parts Identification



Texas Fluorescents Reinvented

A. Identify Fixtures

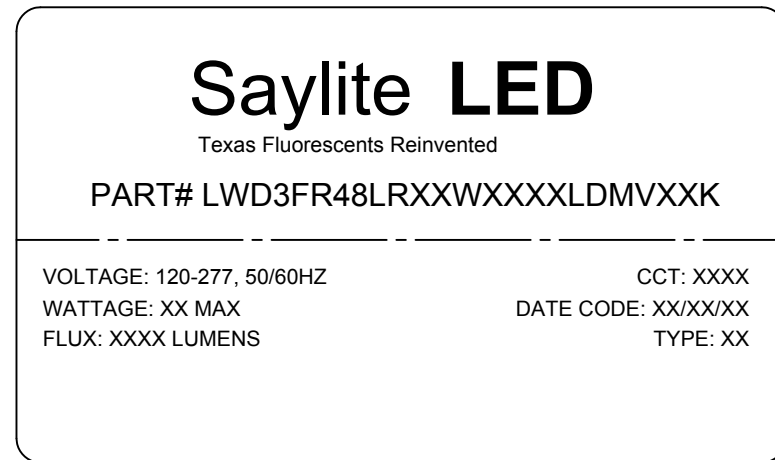

- Use labels found on the box and inside fixture bodies to identify bodies.
- **NOTE:** Locations of labels can vary.
- Remove all fixtures from their boxes.
- Organize fixtures based on their labels at the install location.

B. Tools Needed



Screwdriver



1/8" Drill Bit

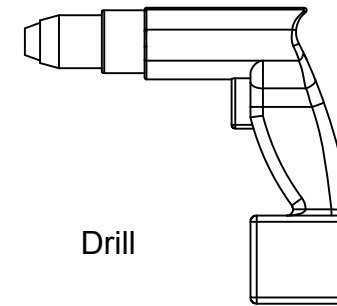

Drill

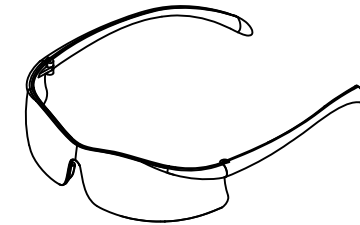

Safety Glasses

- Always use proper safety equipment when installing fixtures.
- Tools shown are recommended for standard install. Tools needed may vary based on actual install location conditions.

C. Identify Parts

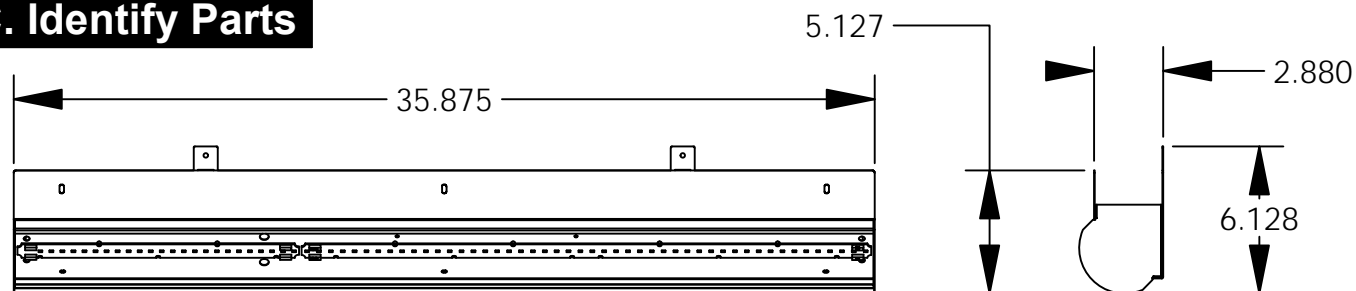

LWD Surface Mount Fixture

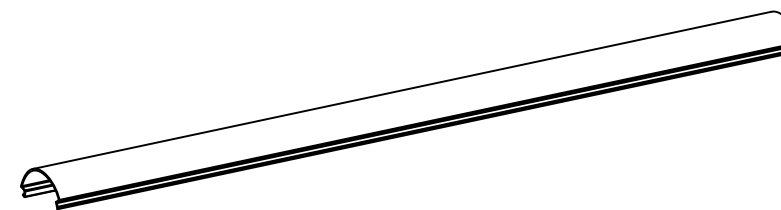

Lens

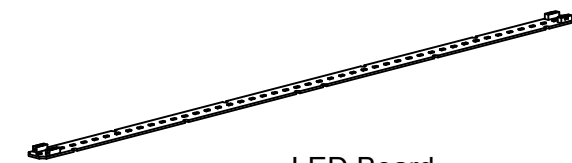

LED Board

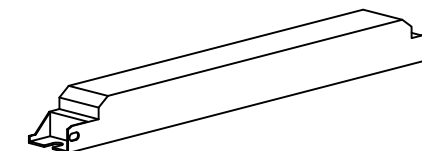

LED Driver

- Read entire install instructions before beginning installation.
- Unpack all components and arrange in order of install steps.
- For help with installation, please contact us at www.saylite.com or call us at (972) 247-3171.

LWD-Retrofit Installation Instructions

WARNINGS

WARNING - RISK OF FIRE OR ELECTRIC SHOCK. LUMINAIRE WIRING, POWER SUPPLY, OR OTHER ELECTRICAL PARTS MAY BE DAMAGED WHEN DRILLING FOR INSTALLATION OF RETROFIT KIT HARDWARE. INSPECT WIRING AND COMPONENTS FOR DAMAGE.

ADVERTENCIA - RIESGO DE INCENDIO O DESCARGA ELÉCTRICA. CABLEADO DE LUMINARIAS, FUENTE DE ALIMENTACIÓN U OTRO LAS PIEZAS ELÉCTRICAS PUEDEN DAÑARSE CUANDO TALADRO PARA LA INSTALACIÓN DEL KIT DE RETROFIT HARDWARE. INSPECCIONE EL CABLEADO Y LOS COMPONENTES POR DAÑO.

WARNING - RISK OF FIRE OR ELECTRIC SHOCK. INSTALL THIS KIT ONLY IN THE LUMINAIRE THAT HAS THE CONSTRUCTION FEATURES AND DIMENSIONS SHOWN IN THE PHOTOGRAPHS AND/OR DRAWINGS AND WHERE THE INPUT RATING OF THE RETROFIT KIT DOES NOT EXCEED THE INPUT RATING OF THE LUMINAIRE.

ADVERTENCIA - RIESGO DE INCENDIO O DESCARGA ELÉCTRICA. INSTALE ESTE KIT SOLO EN LA LUMINARIA QUE TIENE LAS CARACTERÍSTICAS Y DIMENSIONES DE LA CONSTRUCCIÓN MOSTRADO EN LAS FOTOGRAFÍAS Y / O DIBUJOS Y DONDE LA CLASIFICACIÓN DE ENTRADA DEL RETROFIT EL KIT NO EXCEDE LA CLASIFICACIÓN DE ENTRADA DEL LUMINARIA.

DO NOT MAKE OR ALTER ANY OPEN HOLES IN AN ENCLOSURE OF WIRING OR ELECTRICAL COMPONENTS DURING KIT INSTALLATION.

NO HAGA NI ALTERE NINGÚN AGUJERO ABIERTO EN UN RECUBRIMIENTO DE CABLEADO O ELECTRICO COMPONENTES DURANTE LA INSTALACIÓN DEL KIT.



Texas Fluorescents Reinvented

THE RETROFIT KIT IS ACCEPTED AS A COMPONENT OR A LUMINAIRE WHERE THE SUSTAINABILITY OF THE COMBINATION SHALL BE DETERMINED BY AUTHORITIES HAVING JURISDICTION. PRODUCT MUST BE INSTALLED BY A QUALIFIED ELECTRICIAN IN ACCORDANCE WITH THE APPLICABLE AND APPROPRIATE ELECTRICAL CODES. THE INSTALLATION GUIDE DOES NOT SUPERSEDE LOCAL OR NATIONAL REGULATIONS FOR ELECTRICAL INSTALLATIONS.

EL KIT DE RETROFIT SE ACEPTA COMO UN COMPONENTE O UNA LUMINARIA DONDE LA SOSTENIBILIDAD DE LA COMBINACIÓN SERÁ DETERMINADA POR AUTORIDADES CON JURISDICCIÓN. PRODUCTO DEBE INSTALARSE SER UN ELECTRICISTA CALIFICADO DE ACUERDO CON LO APLICABLE Y CÓDIGOS ELÉCTRICOS APROPIADOS. EL LA GUÍA DE INSTALACIÓN NO SUCEDE LOCAL O REGLAMENTOS NACIONALES PARA ELECTRICIDAD INSTALACIONES.

WARNING - RISK OF FIRE OR ELECTRIC SHOCK. INSTALLATION OF THIS RETROFIT KIT REQUIRES A PERSON FAMILIAR WITH THE CONSTRUCTION AND OPERATION OF THE LUMINAIRE'S ELECTRICAL SYSTEM AND THE HAZARD INVOLVED. IF NOT QUALIFIED, DO NOT ATTEMPT INSTALLATION. CONTACT A QUALIFIED ELECTRICIAN.

ADVERTENCIA - RIESGO DE INCENDIO O DESCARGA ELÉCTRICA. LA INSTALACIÓN DE ESTE KIT DE RETROFIT REQUIERE UNA PERSONA FAMILIAR CON LA CONSTRUCCIÓN Y FUNCIONAMIENTO DE LA ELECTRICIDAD DE LAS LUMINARIAS SISTEMA Y EL PELIGRO INVOLUCRADO. SI NO CALIFICADO, NO INTENTE LA INSTALACIÓN. CONTACTE A UN ELECTRICISTA CALIFICADO.

LWD-Retrofit Installation Instructions

WARNINGS (Cont.)



Texas Fluorescents Reinvented

Carefully read the instructions pertaining to your fixture thoroughly. IF YOU HAVE ANY QUESTIONS REGARDING THE PROPER INSTALLATION OR LOCAL CODES, CONSULT A QUALIFIED ELECTRICIAN.	Lisez attentivement les instructions relatives à votre appareil complètement. SI VOUS AVEZ DES QUESTIONS CONCERNANT LES CODES DE POSE OU LOCAUX, CONSULTEZ UN ÉLECTRICIEN QUALIFIÉ.
Injury to persons and damage to the fixture and/or mounting surface may occur if the fixture is pulled from the surface. To reduce risk of injury or damage, mount only to a mechanically sound surface.	Blessure de personnes et dommages à l'appareil et / ou Surface de montage peut se produire si l'appareil est la surface. Pour réduire les risques de blessures ou de dommages, Seulement à une surface mécaniquement saine.
Both cord set and hard wired fixtures are intended for connection to a grounded, three-wire source of supply.	Les ensembles à cordon et les appareils câblés sont destinés Connexion à une source d'alimentation à trois fils mise à la terre.
Install and wire the fixture in locations in accordance with all national, state and local codes.	Installer et câbler l'appareil dans des endroits conformes aux Tous les codes nationaux, étatiques et locaux.
To avoid shock hazard, do not work with live electrical wires.	Pour éviter tout risque d'électrocution, ne pas travailler avec des fils.
Do not install outdoors or in applications other than intended use.	Ne pas installer à l'extérieur ou dans des applications autres que L'utilisation prévue.
Ensure fixture is properly grounded before testing.	Assurez-vous que l'appareil est correctement mis à la terre avant le test.
This fixture is intended for dry applications only.	Ce luminaire est réservé aux applications sèches.
WARNING – Risk of fire or electric shock. Install this kit only in luminaires that have the construction features and dimensions shown in the photographs and/or drawings and where the input rating of the retrofit kit does not exceed the input rating of the luminaire.	AVERTISSEMENT – RISQUE D'INCENDIE OU DE CHOC ÉLECTRIQUE. L'INSTALLATION DE CE NÉCESSAIRE DE MODERNISATION EXIGE UNE PERSONNE FAMILIÈRE AVEC LA CONSTRUCTION ET LE FONCTIONNEMENT DU SYSTÈME ÉLECTRIQUE DU LUMINAIRE ET DES RISQUES ASSOCIÉS. TOUTE PERSONNE QUI N'EST PAS QUALIFIÉE NE DOIT FAIRE AUCUNE TENTATIVE D'INSTALLATION ET DOIT CONTACTER UNE PERSONNE QUALIFIÉE.
WARNING – To prevent wiring damage or abrasion, do not expose wiring to edges of sheet metal or other sharp objects.	AVERTISSEMENT – AFIN DE PRÉVENIR L'ENDOMMAGEMENT OU L'ABRASION DES CÂBLES, ÉVITER TOUT CONTACT ENTRE CES DERNIERS ET LE BORD D'UN OBJET TRANCHANT TEL QU'UNE TÔLE.
DO NOT MAKE OR ALTER ANY OPEN HOLES IN AN ENCLOSURE OF WIRING OR ELECTRICAL COMPONENTS DURING KIT INSTALLATION.	IL EST INTERDIT DE FAIRE OU DE MODIFIER UNE OUVERTURE DANS UN BOÎTIER DE CÂBLAGE OU DE COMPOSANTS ÉLECTRIQUES AU COURS DE L'INSTALLATION DU NÉCESSAIRE.
THIS RETROFIT KIT IS ACCEPTED AS A COMPONENT OF A LUMINAIRE WHERE THE SUITABILITY OF THE COMBINATION SHALL BE DETERMINED BY AUTHORITIES HAVING JURISDICTION.	LE NÉCESSAIRE DE MODERNISATION EST ACCEPTÉ À TITRE DE COMPOSANT D'UN LUMINAIRE LORSQUE LA PERTINENCE DE LA COMBINAISON DOIT ÊTRE DÉTERMINÉE PAR PAR LES AUTORITÉS COMPÉTENTES.



WARNING: THIS PRODUCT MUST BE INSTALLED IN ACCORDANCE WITH THE APPLICABLE INSTALLATION CODE BY A PERSON FAMILIAR WITH THE CONSTRUCTIONS AND OPERATIONS OF THE PRODUCT AND THE HAZARDS INVOLVED.



ATTENTION: CE PRODUIT DOIT ÊTRE INSTALLÉ CONFORMÉMENT À L'INSTALLATION APPLICABLE CODE PAR UNE PERSONNE FAMILIALE AVEC LES CONSTRUCTIONS ET LES OPÉRATIONS PRODUIT ET LES DANGERS ENVOLVÉS.



WARNING: RISK OF FIRE; MINIMUM OF 90°C SUPPLY CONDUCTOR SHOULD BE USED. CONSULT A QUALIFIED ELECTRICIAN TO ENSURE CORRECT BRANCH CIRCUIT CONDUCTOR.



ATTENTION: RISQUE D'INCENDIE; MINIMUM DE 90 ° C DE CONDUCTEUR D'ALIMENTATION DOIT ÊTRE UTILISÉ. CONSULTEZ A ELECTRICIEN QUALIFIE POUR ASSURER UN CONDUCTEUR DE CIRCUIT DE BRANCHE CORRECT.



WARNING: TO AVOID ELECTRIC SHOCK HAZARD, DISCONNECT THE POWER AT THE PANEL BOARD (CIRCUIT BREAKER BOX) BEFORE BEGINNING INSTALLATION.



ATTENTION: POUR ÉVITER TOUT RISQUE D'ÉLECTROCUTION, DÉBRANCHEZ L'ÉNERGIE DU PANNEAU (CIRCUIT BREAKER BOX) AVANT DE COMMENCER L'INSTALLATION.



WARNING: TO AVOID FIRE HAZARD RISK, WHEN INSTALLING HARD WIRED UNITS, BE AWARE IF SUPPLY WIRES ARE LOCATED WITHIN THREE INCHES OF BALLAST. IF SO, USE WIRE RATED FOR AT LEAST 90°C (194°F). IF UNSURE, CONSULT A QUALIFIED ELECTRICIAN BEFORE INSTALLING.



ATTENTION: POUR ÉVITER LE RISQUE DE RISQUE D'INCENDIE, LORS DE L'INSTALLATION D'UNITÉ CÂBLÉE, CONSULTEZ SI L' APPROVISIONNEMENT LES FILS SONT SITUÉS DANS LES TROIS POUCHES DE BALLAST. SI CELUI-CI, UTILISEZ LE FIL POUR UN AU MOINS 90 ° C (194 ° F). SI VOUS ÊTES SÛR, CONSULTEZ UN ÉLECTRICIEN QUALIFIÉ AVANT D'INSTALLER.

LWD-Retrofit Installation Instructions

WIRING DIAGRAM

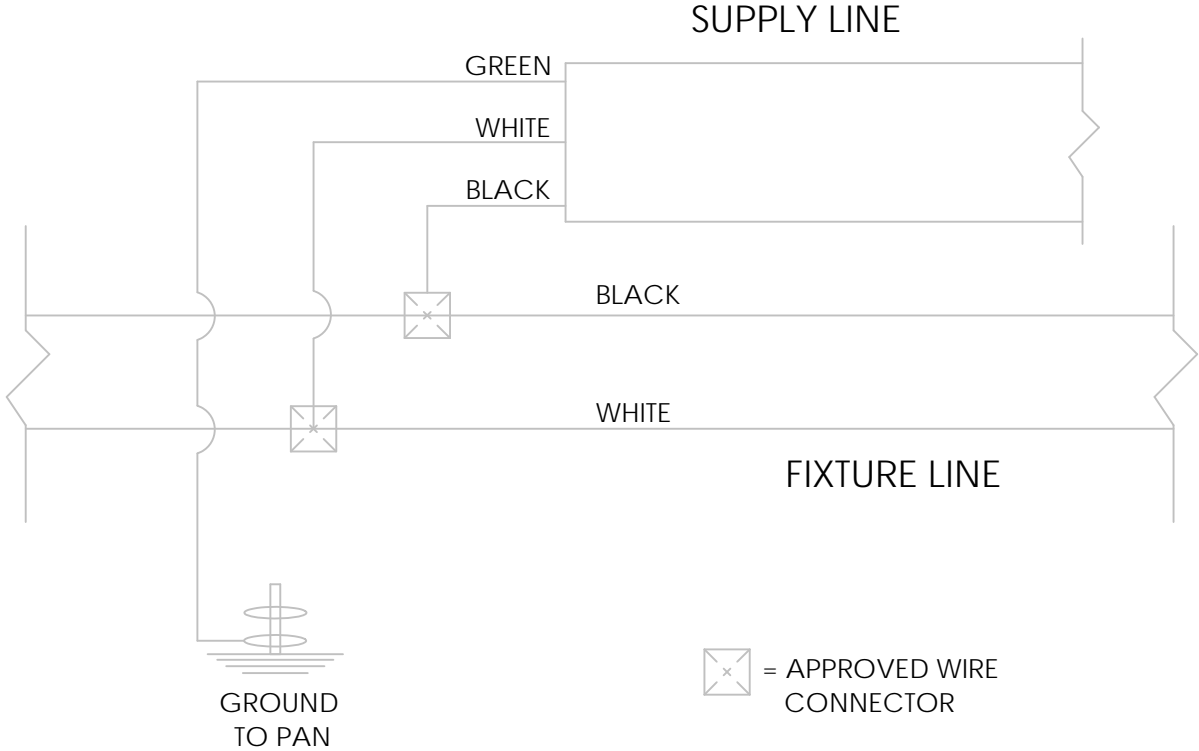

LWD-Retrofit Installation Instructions

Step 1 - Remove Existing Components



REMINDER: TO AVOID ELECTRIC SHOCK HAZARD, DISCONNECT THE POWER AT THE PANEL BOARD (CIRCUIT BOX) BEFORE BEGINNING INSTALLATION!



Remove Lamps



Remove Ballast Cover

- Reminder: To avoid electric shock, disconnect the power at the panel before beginning installation.
- Remove all existing lamps.
- Remove the ballast cover from the fixture.



Remove Sockets



Remove Socket Bars



Remove Ballast

- Remove the sockets from the socket bars.
- Remove the socket bars from the pan.
- Remove the ballast from the pan.

Items Used In This Step

LWD-Retrofit Installation Instructions

Step 2 - Prepare The Channel

A. Drill Pilot Holes

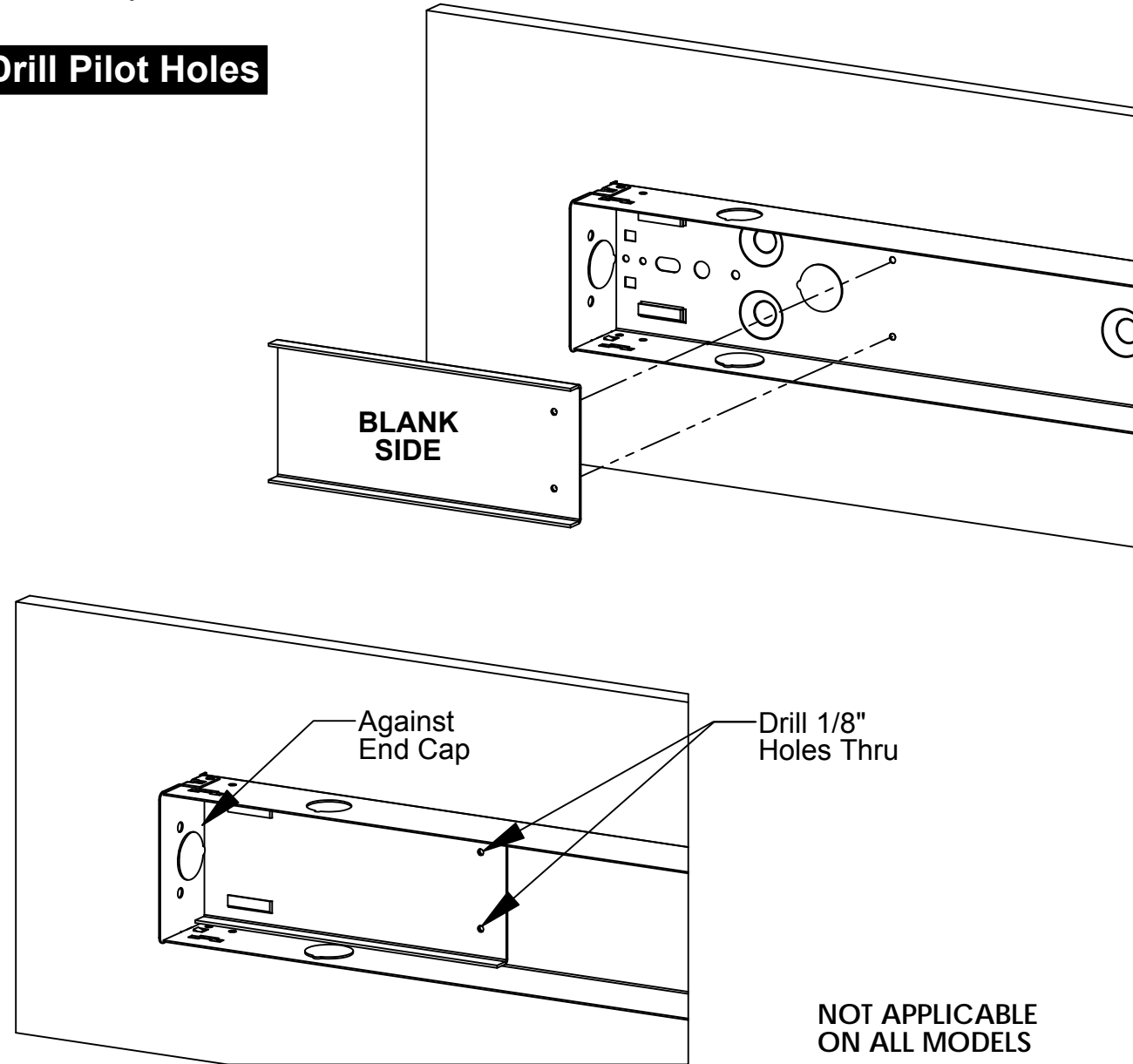

- Position the Hole Template inside the channel as shown, with blank side up against end cap.
- Secure the template to the bottom of the channel. Drill 1/8" holes through. Repeat for opposite side.

Items Used In This Step



1/8" Drill Bit

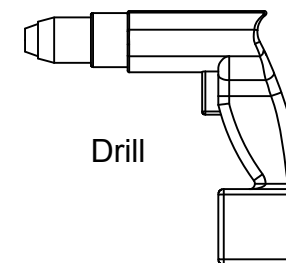

Drill



Texas Fluorescents Reinvented

B. Secure Angle Bracket

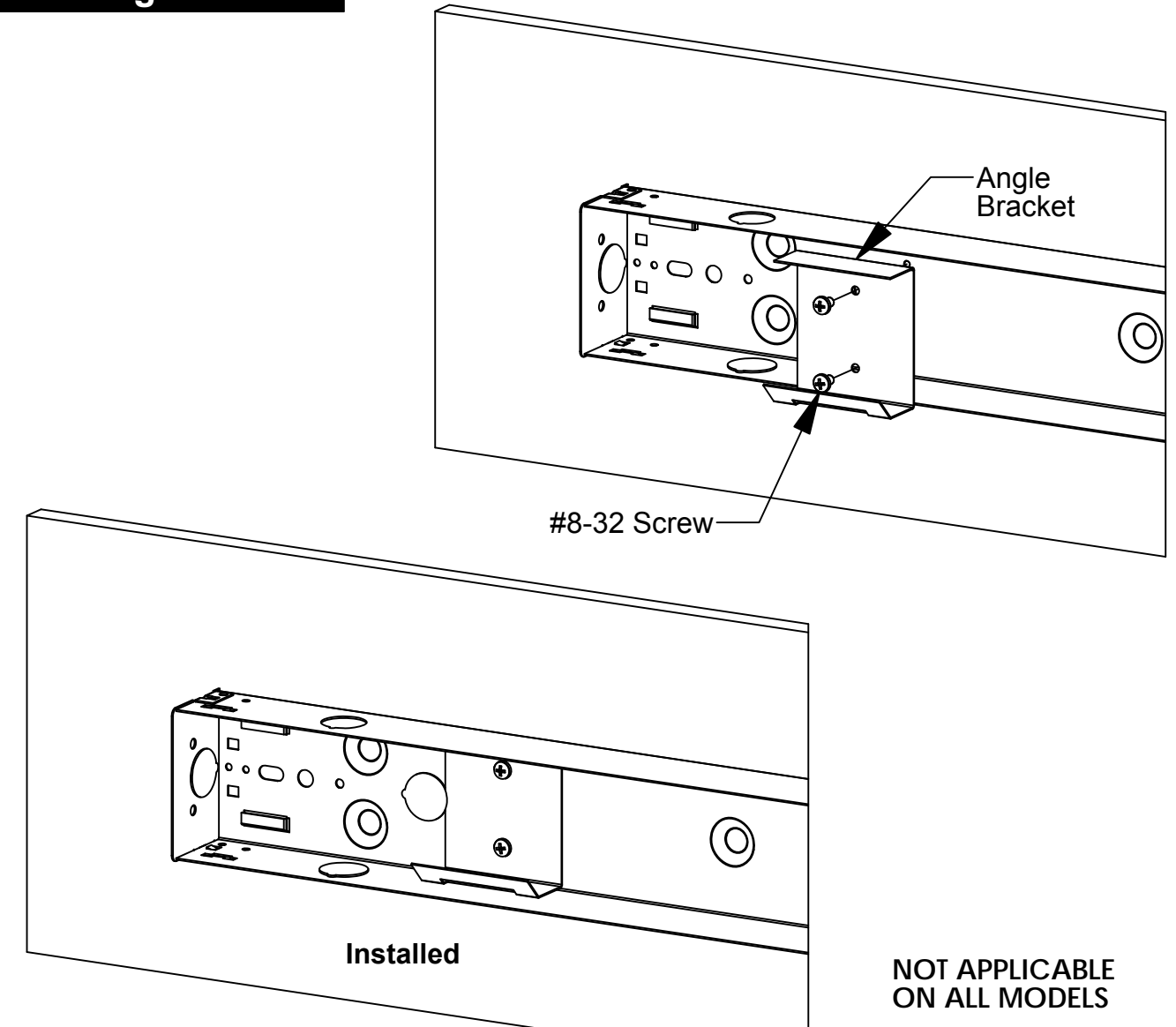

- Install the angle bracket to the channel as shown above. Secure with (2) #8-32 screws.
- Repeat for the opposite side of the bracket.

LWD-Retrofit Installation Instructions

Step 3 - Install The Fixture

A. Connect Power

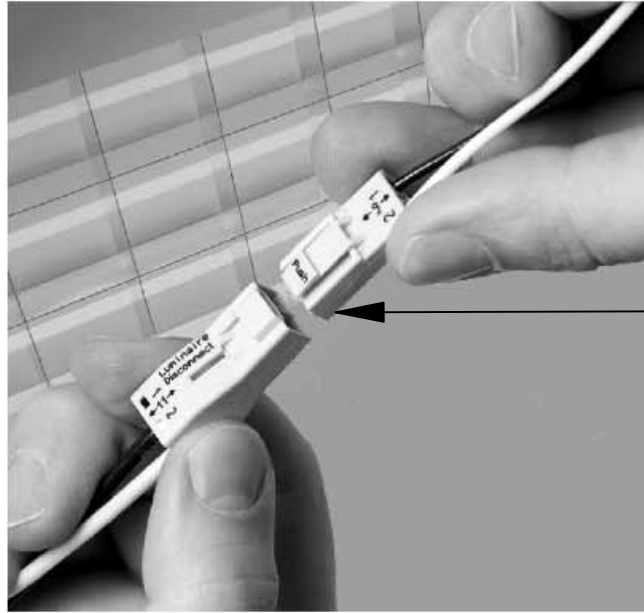

Quick Disconnect

WIRING LEGEND		
Black	Hot	Line Voltage
White	Neutral	Line Voltage
Green	Ground	
Gray	Dimming	0-10V DC
Violet	Dimming	0-10V DC

- Wire the fixture to the incoming supply using provided quick clip as shown.
- For dimming option, refer to the wiring legend above as needed.
- **Note:** Use UL approved connectors only. Follow all local, state and national codes

Items Used In This Step

B. Install Fixture

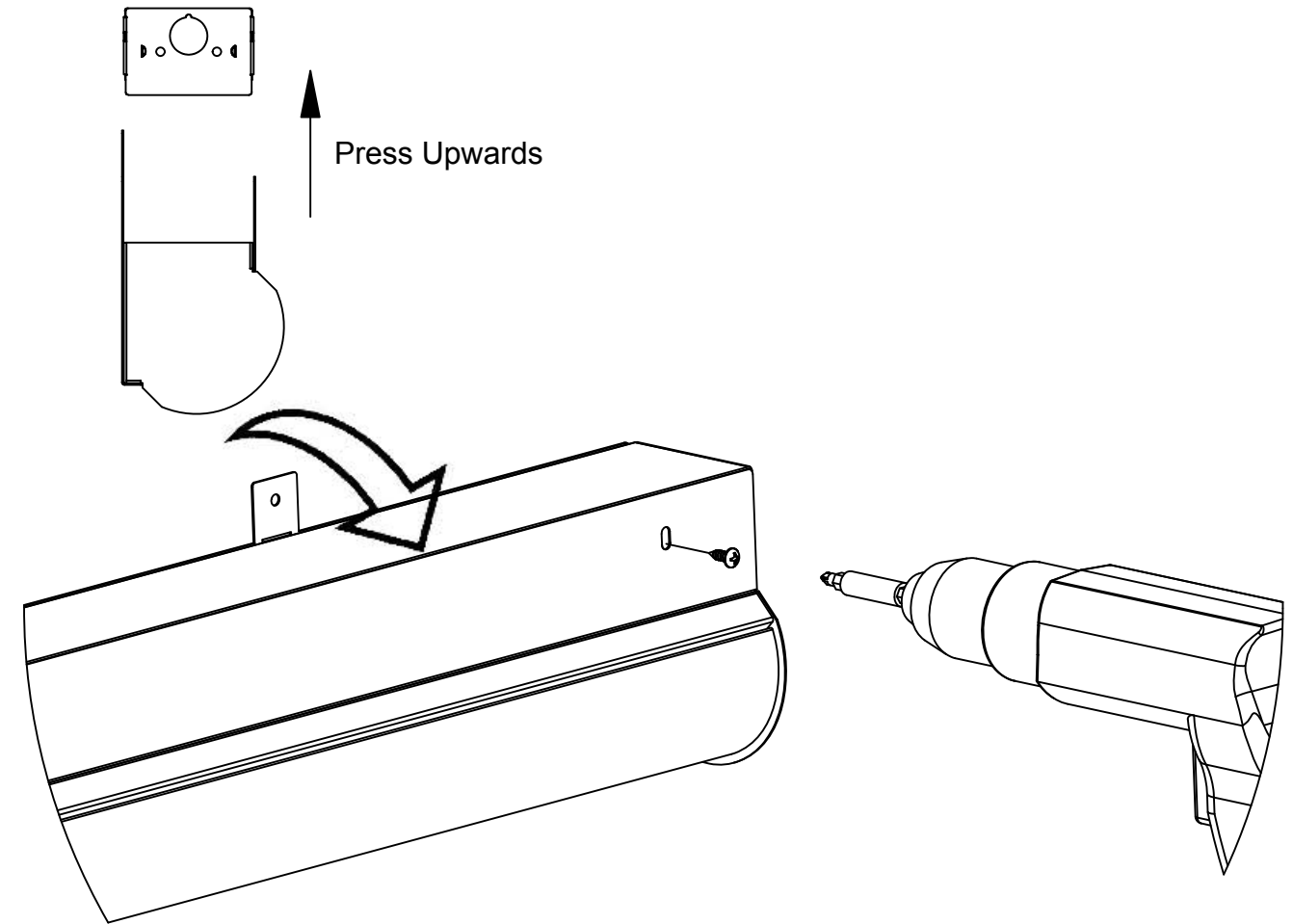

- Press the retrofit fixture straight up in to the strip as shown, the tabs show go behind the strip.
- Secure the fixture to the strip on the side using (3) screws (by others).
- Hand bend the tabs 90° and secure to the top using (2) screws. Install is now complete.