



Series ATB

Architectural Tall Bollard

Series ATB Architectural Tall Bollards represent the latest in LED design for site and architectural lighting, strip malls/centers and multi-family exterior applications. This garden luminaire makes a bold, stylish statement. Available in optional RGB and with custom text on the galvanized bollard.

CONSTRUCTION

11.5 feet tall with a 4 foot diffuser section of durable acrylic. Bolted with a mounting plate onto a foundation provided by the customer or an anchorage unit made of hot-dip galvanized steel with aluminum anodized finish.

DIMENSIONS

Diameter: 7"
Height: 137.8"

FEATURES & BENEFITS

- Highest grade structural steel
- A single piece of formed steel welded longitudinally
- Chemically-treated to ensure maximum paint adhesion
- Galvanized: 90.55"
- Acrylic Lens: 47.25"
- Wall Thickness: 0.15"
- Aluminum anodized finish
- 80 watt
- Non-dimmable
- 4000K standard; consult factory for RGB option
- 2 Year Warranty



DRAWINGS & IMAGES

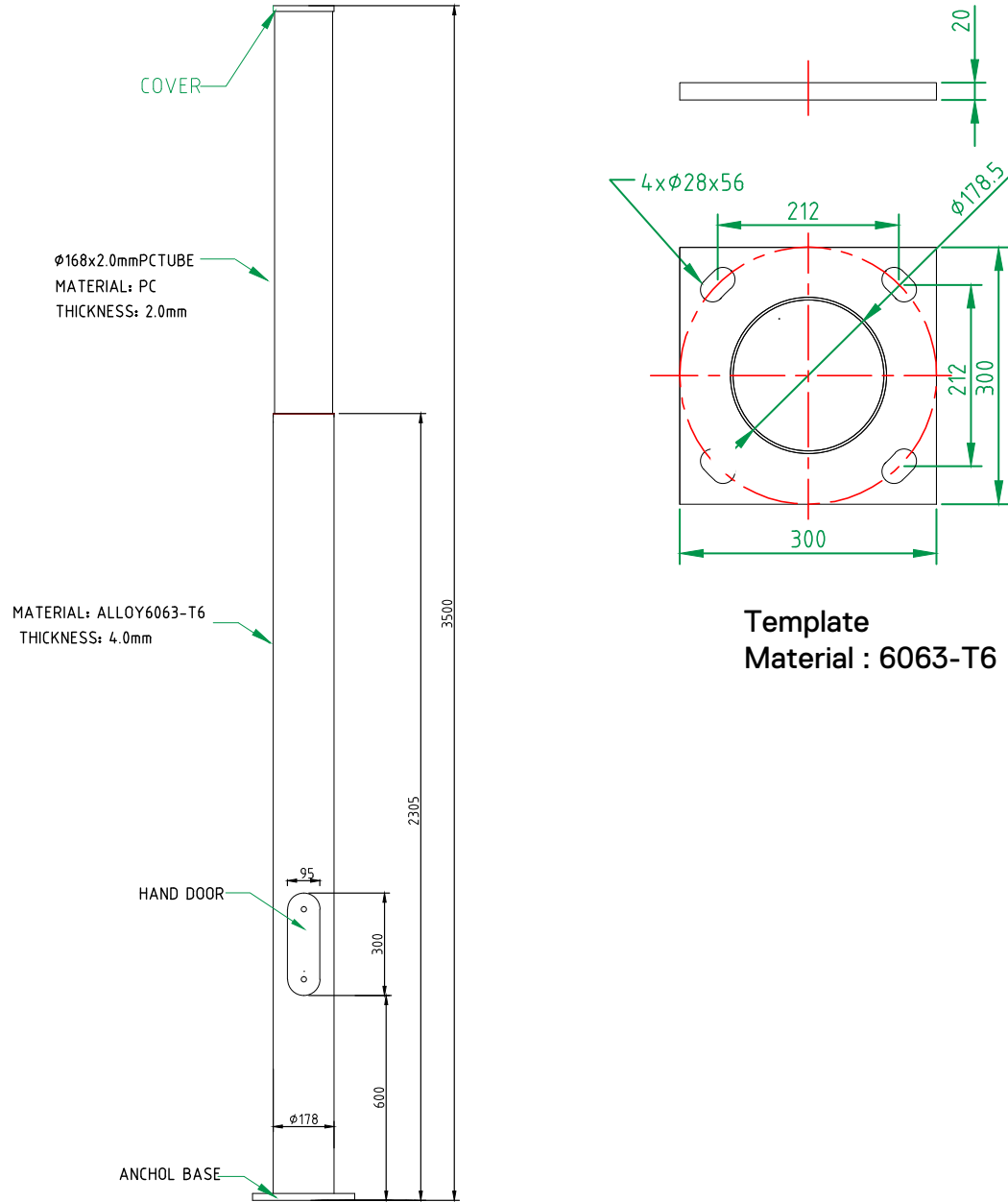

PRODUCT NUMBERS

ITEM NUMBER	DESCRIPTION
ATBL80WMV40K	Architectural Tall Bollard 80W (LED) Cassiopeia Single White Color with Non-dimmable Driver 4000K with J-Bolt. Aluminum Anodized Finish. Overall Height: 137.8"; Wall Thickness: 0.15". (Dimension: 7" Diameter; 90.55" Galvanized; 47.25" Acrylic; 12" Square)